



Series 90A-LC Annunciator

FOR POWER GENERATION, TRANSMISSION & DISTRIBUTION, PETROLEUM, PETROCHEMICAL, AND OTHER PROCESS INDUSTRIES



ANNUNCIATOR

The Series 90A-LC is an economical LED Display for remote annunciator applications. The display can be connected to other annunciator logic systems or can be directly connected to a PLC or DCS System.

Compact Size

The annunciator and all electronics are self contained within a compact frame less than 7" deep.

Reliability

Every Series 90A-LC Annunciator is equipped with low power, long life LED's. The brightness exceeds standard incandescent bulbs and they last years longer.

Flexible Design

The window legends are printed on standard transparency film, making it easy to change legends at any time

FEATURES AND BENEFITS

- LED Illumination
- Laser Printed Legends
- Compact Size
- Screw Terminal Barrier Block



Series 90A-LC Ordering Information

TYPICAL MODEL NUMBER (coded by color)

Series 90A-LC -PM -3H -6W -NPB -2 -36 -W -TP

Code Description

Series 90A-LC Series 90A-LC Alarm Annunciator

Mounting Options

PM Semi-Flush Panel Mounting
 PC Semi-Flush Panel Mounting with Rear Cover
 RK 19" Rack Mounting (5 Wide Systems Only)
 S Surface (Wall) Mounting (1H to 5H x 2W to 5W)

Number of Cells High – (1-13 H)

Number of Cells Wide – (1-13 W)

Pushbutton Controls

INTB Integral Test Pushbutton
 NPB No Integral Pushbutton

Window Size

4 Quad Size, 4 Inputs Per Cell, Each 1.5"H x 1.5"W
 3 Third Size, 3 Inputs Per Cell, Each 1.0"H x 3.0"W
 2 Half Size, 2 Inputs Per Cell, Each 1.5"H x 3.0"W
 1 Full Size, 1 Input Per Cell, Each 3.0"H x 3.0"W
 IMW Intermixed Window Size (Must Include Matrix)

Number of Active Alarm Points

Window Colors

W White Window Filter
 R Red Window Filter
 A Amber Window Filter
 G Green Window Filter
 B Blue Window Filter
 IMC Intermix Color

Window Legends

TP Legends Printed on Transparency Film (Field Changeable)
 ENG Legends Are Engraved on the Window Frames

SPECIFICATIONS

INPUT

Field Contacts, Switched Inputs
Voltage: 24 VDC

Current Requirements per Input:

| Window Size (inputs/cell) | # of LED's (per Input) | Switched Current @24VDC |
|---------------------------|------------------------|-------------------------|
| 1 | 8 | 0.163 A |
| 2 | 4 | 0.082 A |
| 3 | 2 | 0.041 A |
| 4 | 2 | 0.041 A |

CONTROLS

Lamp Test
Voltage: 24 VDC

DISPLAY

LED

- White LED, minimum two per Window

Window Sizes

- Quad: 1.5"h x 1.5"w (38 x 38mm)
- Third: 1.0"h x 3.0"w (25 x 76mm)
- Half: 1.5"h x 3.0"w (38 x 76mm)
- Full: 3.0"h x 3.0"w (76 x 76mm)

Window Color

- White, red, amber, yellow, green, and blue

Legends

- Laser printed on transparency film or engraved windows

CONNECTIONS

Input/Output Terminals

- Fixed barrier terminal block, 12 GA (2.5mm) maximum, ring, spade or bare wire termination

MECHANICAL

Mounting

- Semi-flush panel mounting
- 19" rack mounting
- Wall (surface) mounting

Weight

- 1.5 lbs per cell (0.34 kg per cell)

ENVIRONMENT

Operating Temperature Range:

- -4 to 122°F (-20 to 50°C)

Humidity:

- 20-95% RH

Isolation:

- 1950 VDC or 1400 VAC input to case

Panel Mounting Details inches (mm)

| Cells H or W | Overall H or W | Panel Cut-Out H or W |
|--|----------------|----------------------|
| 1 | 5.0 (127) | 4.06 (103) |
| 2 | 8.47 (215) | 7.53 (191) |
| 3 | 11.94 (303) | 11.00 (279) |
| 4 | 15.40 (391) | 14.47 (368) |
| 5 | 18.88 (479) | 17.94 (456) |
| 6 | 22.34 (568) | 21.41 (544) |
| 7 | 25.81 (656) | 24.88 (632) |
| 8 | 29.28 (744) | 28.34 (720) |
| 9 | 32.75 (832) | 31.81 (808) |
| 10 | 36.22 (920) | 35.28 (896) |
| 11 | 39.69 (1008) | 38.75 (984) |
| 12 | 43.16 (1096) | 42.22 (1072) |
| 13 | 46.63 (1184) | 45.69 (1161) |
| Depth behind panel: 6.75", 10" with rear cover | | |

Example: 2 H x 3 W has a cut-out height of 7.53 (191) and a cut-out width of 11.0 (279)

WIRING DIAGRAM

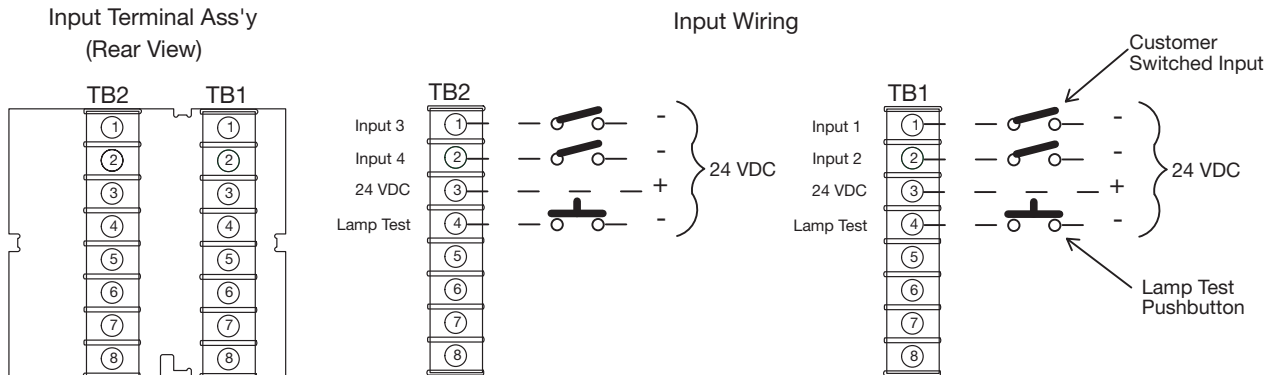

For customer support call:

POWER INSTRUMENTS
255 North Union Street
Rochester, NY 14605
Tel: 585.263.7700
Fax: 585.454.7805
power.sales@ametek.com

HEADQUARTERS
AMETEK Power Instruments
50 Fordham Road
Wilmington, MA 01887
Tel: 978.988.4903
Fax: 978.988.4990
power.sales@ametek.com

EUROPEAN HEADQUARTERS
Unit 15, Lisburn Enterprise Centre
Ballinderry Road
Lisburn, Co Antrim, UK BT282BP
Tel: 44.28.9260.4100
Fax: 44.28.9260.4141
sales@ametekuk.com

ASIA PACIFIC HEADQUARTERS
10 Ang Mo Kio Street 65
#05-12 Techpoint
Singapore 569059
Tel: 65.484.2388
Fax: 65.481.6588



ISO 9001 Certified