



Description & Features:

- Slimline probe is especially suited for applications with restricted space
- Designed for continuous level measurement in water or other liquids with low viscosity
- 316L SS probe with stainless steel sensor for ease in cleaning
- Available ranges from H₂O up to 300 psi
- ±0.35% accuracy rating
- NEMA 6P / IP68
- Approved for outdoor use
- Customizable
- 1 year warranty

Applications:

- Appropriate for all hazardous areas where an intrinsically safe rating is required, including oil & gas, chemical and sewage treatment installations

Specifications

Output Signal	Standard 2-wire: 4-20 mA / Vs = 12-36 Vdc
Accuracy	±0.35% FSO BFSL Optional nominal pressure > 5 psi: <±0.25% FSO BFSL
Permissible Load	$R_{max} = [(V_s - V_{s\ min}) / 0.02]$ Ohm
Influence Effects	Supply: 0.05% FSO / 10 V Load: 0.05% FSO / kOhm
Long-term Stability	<±0.1% FSO/yr
Response Time	<10 ms
Permissible Temperatures	Medium: 14°F to 158°F (-10°C to 70°C) Storage: -13°F to 158°F (-25°C to 70°C)
Reverse Polarity Protection	No damage. No function.
Electromagnetic Protection	Emission and immunity according to EN 61326
Electrical Connection	Cable with sheath material*: PVC grey, PUR black, FEP black
Housing	316Ti SS
Seals	FKM / EPDM
Diaphragm	316L SS
Weight	100 g (without cable)
Current Consumption	25 mA max
Connecting Cables	Cable capacitance: Signal line/shield and signal line/signal line: 160 pF/m Cable inductance: Signal line/shield and signal line/signal line: 1 µH/m
Enclosure Rating	NEMA 6P / IP68

Thermal Errors (Offset and Span)

Nominal Pressure (psi)	<1	<4	<5	<15	>15
Tolerance Band (% FSO)	<±2	<±1.5	<±1	<±1	<±0.75
TC, Average (% FSO/10K)	±0.3	±0.2	±0.14	±0.1	±0.07
Compensated Range	32°F to 122°F 0°C to 50°C		32°F to 158°F 0°C to 70°C		

Pin Configuration

Electrical Connection		Cable Colours
2-wire system	Supply +	White
	Supply -	Brown
	Ground	Yellow/green (shield)

Order Codes

Range	Over-pressure	Burst Pressure	Code
0/50" water	15 psi	22 psi	LM3W05
0/100" water	15 psi	22 psi	LM3W10
0/150" water	15 psi	22 psi	LM3W15
0/200" water	15 psi	22 psi	LM3W20
0/300" water	15 psi	22 psi	LM3W30
0/400" water	15 psi	22 psi	LM3W40
0/5 psi	15 psi	44 psi	LM3005
0/10 psi	44 psi	109 psi	LM3010
0/15 psi	44 psi	109 psi	LM3015
0/25 psi	87 psi	218 psi	LM3025
0/50 psi	290 psi	218 psi	LM3050
0/100 psi	290 psi	725 psi	LM3100
0/200 psi	870 psi	1,740 psi	LM3200
0/300 psi	1,450 psi	1,740 psi	LM3300

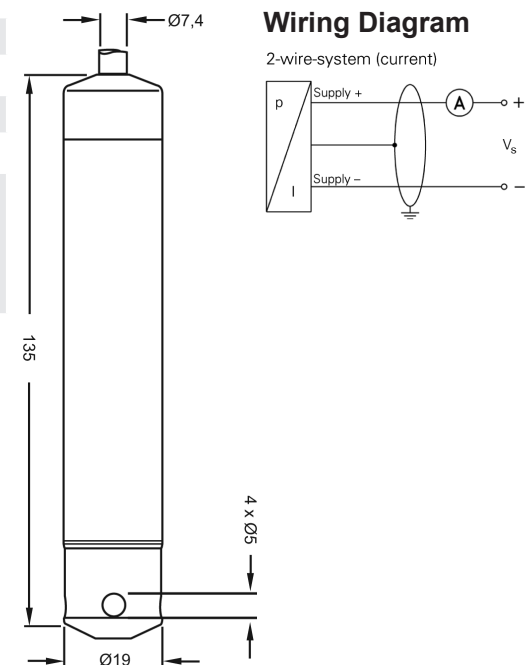

Note: Measurements are in mm. Cable not included (specify type and length)

* Cable with integrated air tube for atmosphere pressure reference